

1968-1972 General Motors Chevelle OEM Replacement Frame

202407

- **AFCO frame can be widened to "A" but must be centered.**
- **Dimensions are to either the top or bottom surface of the frame rail as indicated.**
- **Some dimensions may not apply as frame can be trimmed for front bumper.**
- **All dimensions must be within 0.250-inch tolerance. Exception is variances officials verify as crash damage.**

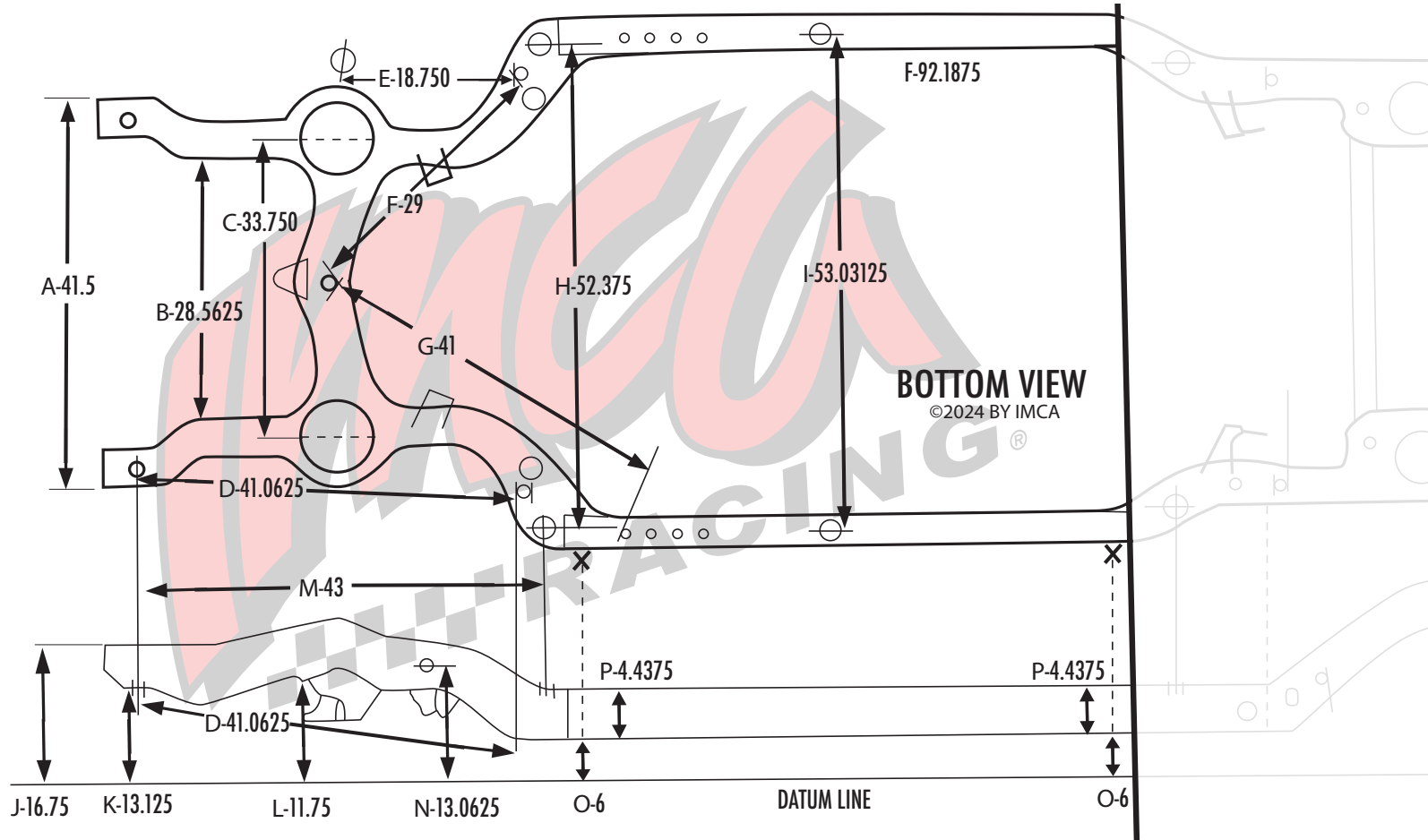

- A.** 41.5 - inches to outside of frame rail
- B.** 28.5625 - inches between side rails at lower steering gear bolt and idler arm mounting surface.
- C.** 33.75", 1/2" tolerance measured at centerline of weight jack at top of frame.
- D.** 41.0625 - inches from center of hole (frame horn bottom), to front edge of hole.

- E.** 18.750 - inches from center of lower ball joint grease fitting, to front edge of hole. Maximum tolerance of 0.5 inches on each side, with a maximum difference of 1 inch from side to side.
- F.** 29 - inches from rear edge of hole, to front edge of hole.
- G.** 41 - inches from rear edge of hole, to front edge of hole.
- H.** 52.375 - inches from center of hole to center of hole.
- I.** 53.03125 - inches from center of hole to center of hole.
- J.** 16.75 - inches to top surface of side rail.
- K.** 13.125 - inches to bottom surface of side rail.

- L.** 11.75 - inches from bottom surface of side rail (just forward of coil spring opening) to datum line.
- M.** 43 - inches measured from center of hole to center of hole.
- N.** 13.0625 - inches center of hole to datum line.
- O.** Locations for measuring ride height. Dimensions J, K, L and N should be measured at 6 inch ride height.
- P.** 4.4375 - inches from top to bottom of side rail surface.

